

NO.	REVISION HISTORY	DATE	SIGNED	CHECKED	APPROVED
A	lead wire length review (510→360), statements review	14.01.16	Fujimoto	Kimura	Toyokawa
B	Element change (FEA-EA041→FEA-EA046), Specifications change	17.08.31	Y.Fujimoto		

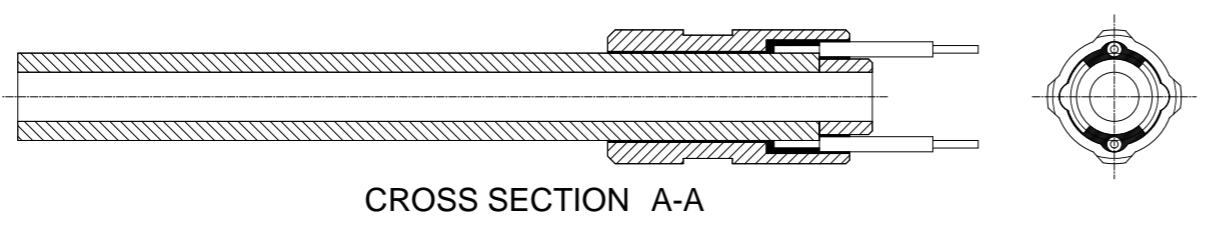
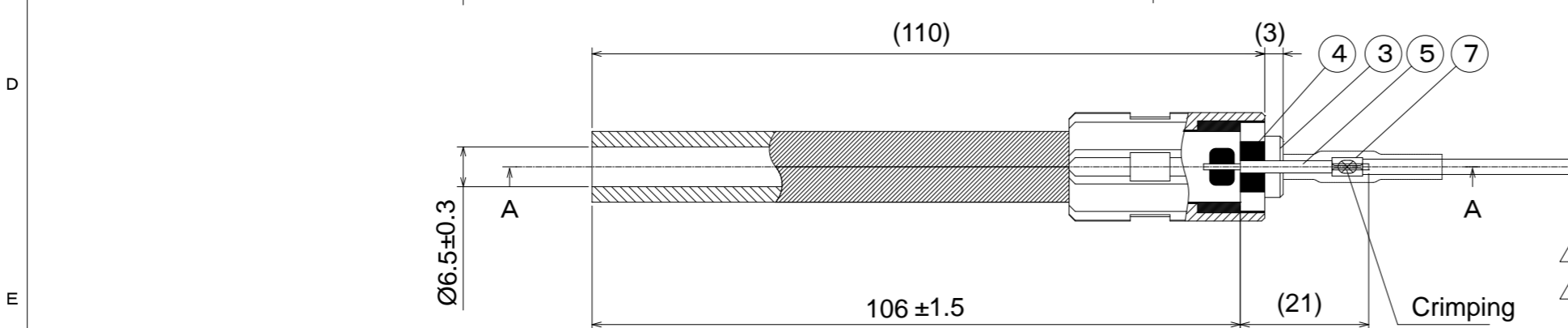
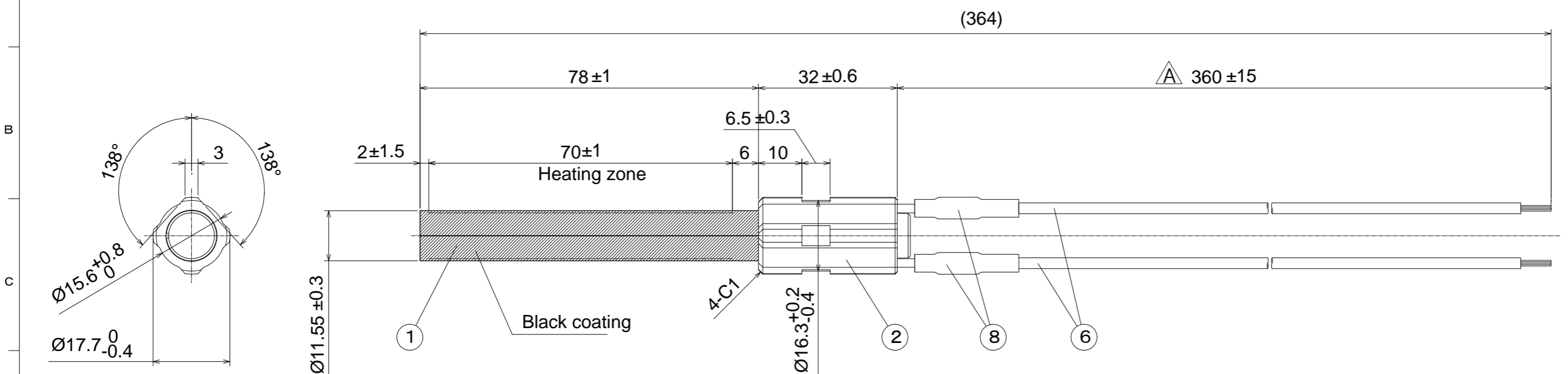

(Specifications)

Properties	Value	Condition
Voltage	AC230V ±15%	
1.Rising time 2.Inrush current 3.Minimum Wattage 4.Minimum temperature	820°C within ≥60s ≥6.7A ≤280W ≤870°C	Applied at AC230V and 23°C ambient temperature
Normal temperature resistance	40.15~49.13Ω	23±1 °C ambient temperature
Insulation resistance	≤50MΩ	Applied at both side of Heating element DC500V at normal temperature and humidity
Withstand voltage	Current Leakage ≥5mA	Applied at both side of Heating element AC1500V for 1 s at normal temperature and humidity rate
Caulking strength (Nickel wire and lead wire)	≤29.4N	The nickel wire has been clamp and the lead part has been tested with push-pull gauge
Discontinuous conduction (Heating element)	Without break	Applied at 264V for 4 min On/5 min off (Forced cooling) for over 3000 cycles.

NO.	NAME	PCS.	DRAWING NO.	MATERIAL/DIMENSION	MODEL NUMBER	OTHER
8	HEAT SHRINKABLE TUBE	2	FEA-TS011	SST, Ø4x25L	SILICONE	180°C
7	CONNECTOR	2		Cu, tin-plating	29071-1	29071-1
6	LEAD WIRE	2	FEA-RG092	RS-GE, 0.5SQ, W	SILICONE-GLASS	180°C
5	INSULATOR TUBE	2	FEA-TP003	PTFE, AWG18-15L		
4	CERAMIC-SEALING			FUJICERAM-W		FKK
3	CERAMIC CAP	1	FEA-GA518	ALUMINA 95		non-Glaze
2	INSULATOR	1	FEA-GA516	ALUMINA 95		non-Glaze
1	HEATING ELEMENT (PL)	1	FEA-EA046	ALUMINA(A473)	B/240V-FCL	

(Statements)

1. This product comply with RoHS and REACH standard.

NAME				PSx-2-240-B	
				(FKK-Standard Pellet system heater)	
MATERIAL			DATE		
			2013.5.20		
APPROVED	T.Murakami	THIRD ANGLE	CODE		
CHECKED	R.Toyokawa				
CHARGED	S.Kimura				
DESIGNED	R.Toyokawa	SCALE	DRAWING NO.		REV
DRAWN	R.Toyokawa	1 : 1	IBA-HH005		B

Proprietary statement This drawings is the proprietary of FKK Corporation. In case of non-respect of the present term, FKK may take action and ask for damages.

**FKK Corporation**